

SISTEMI SCORREVOLI PER PORTE

SISTEMA INVISIBILE BREVETTATO MAGIC 2



Magic2 Il sistema invisibile originale per porte scorrevoli

80 kg

N.2 Fermi ammortizzati

Larghezza porta personalizzabile

Sistema brevettato

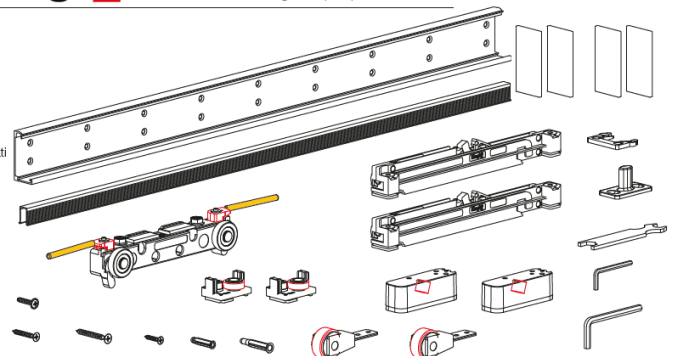

| OLD CODE | NEW CODE | |
|-------------|-------------|---------|
| MAGIC2/1100 | K.0031.1.01 | 1100 mm |
| MAGIC2/1800 | K.0031.2.01 | 1800 mm |



Guida inferiore silenziosa

Per migliorare ancor di più lo scorrimento, il sistema Magic2 integra una guida inferiore rinforzata in zama (resistente e versatile), che scorre in un profilo in plastica molto silenzioso.

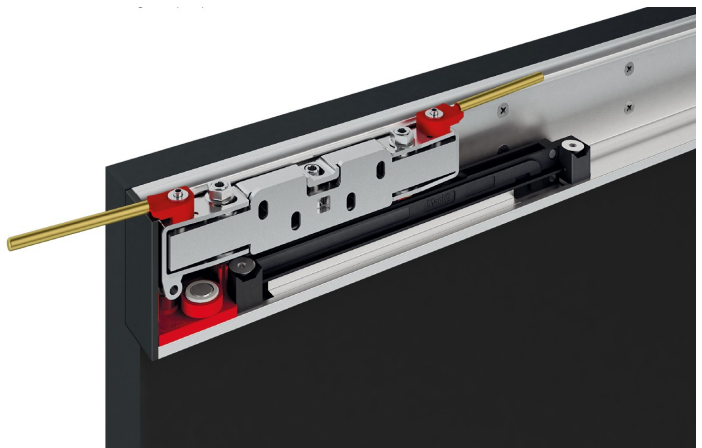

DESCRIZIONE DELLE LAVORAZIONI

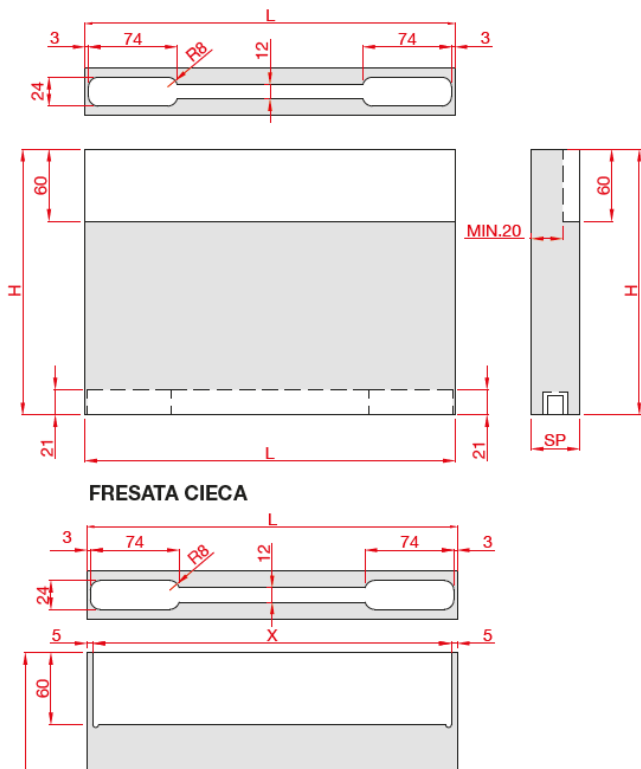

FRESATA CIECA

DESCRIZIONE MISURE

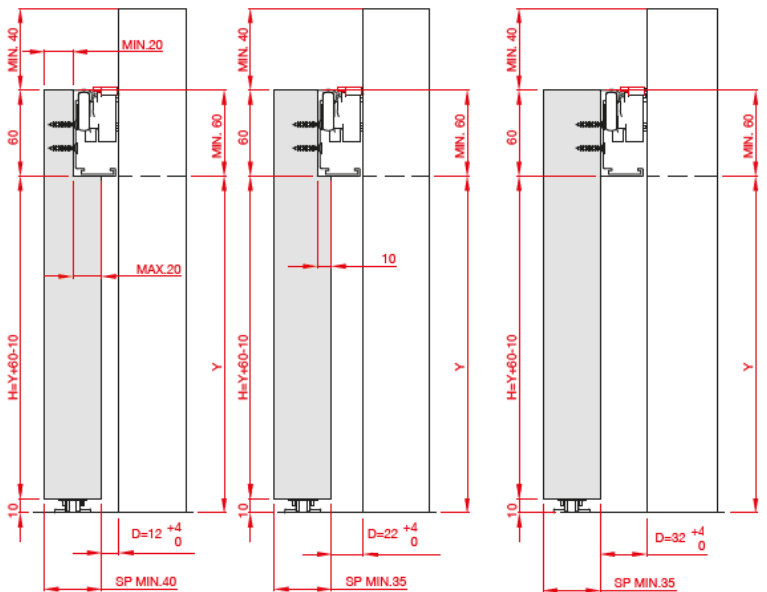

SISTEMI SCORREVOLI PER PORTE

POSIZIONAMENTO DEGLI ACCESSORI (POSIZIONE STANDARD)

B=0mm (Min.)
B=50mm (Suggested/Sugerito)

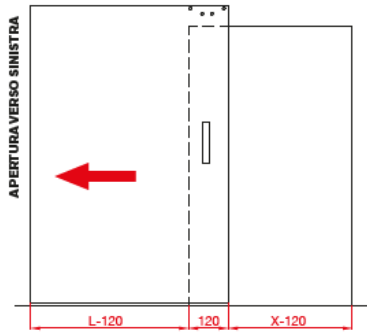

MAGIC2/1100 (K.0031.1.01)

B=0
X= MIN. 800 (L=850)
X= MAX. 1050 (L=1100)

B=50
X= MIN. 800 (L=900)
X= MAX. 1000 (L=1100)

MAGIC2/1800 (K.0031.2.01)

B=0
X= MIN. 800 (L=850)
X= MAX. 1750 (L=1800)

B=50
X= MIN. 800 (L=900)
X= MAX. 1700 (L=1800)

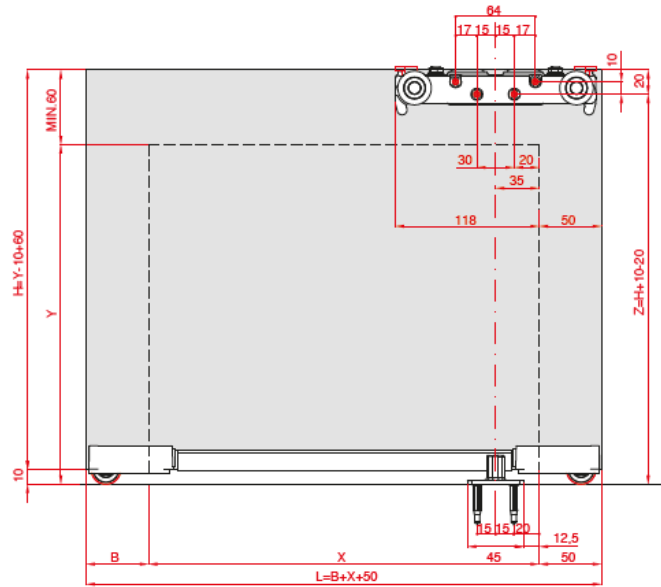

POSIZIONAMENTO DEGLI ACCESSORI (POSIZIONE INTERMEDIA)

B=50mm (Suggested/Sugerito)

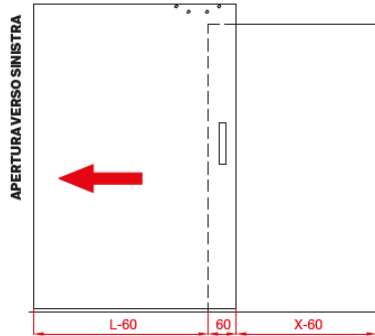

MAGIC2/1100 (K.0031.1.01)

B=0
X= MIN. 740 (L=850)
X= MAX. 990 (L=1100)

B=50
X= MIN. 740 (L=900)
X= MAX. 940 (L=1100)

MAGIC2/1800 (K.0031.2.01)

B=0
X= MIN. 740 (L=850)
X= MAX. 1690 (L=1800)

B=50
X= MIN. 740 (L=900)
X= MAX. 1640 (L=1800)

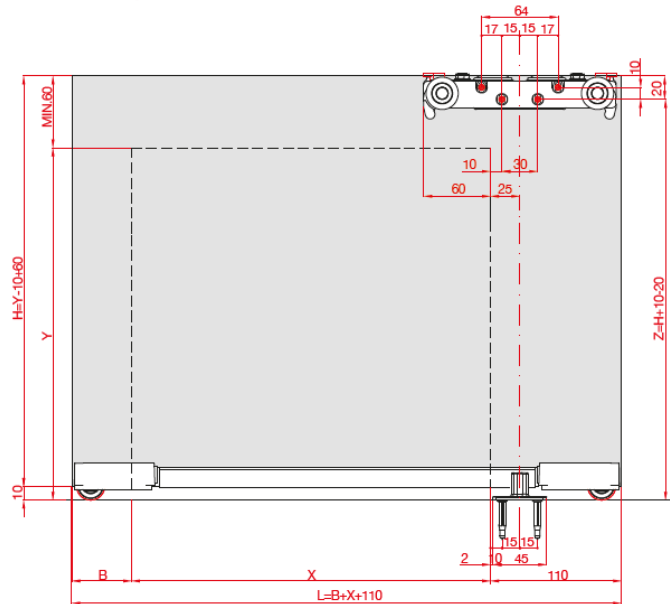

POSIZIONAMENTO DEGLI ACCESSORI (POSIZIONE APERTURA TOTALE)

B=0mm (Min.)
B=50mm (Suggested/Sugerito)

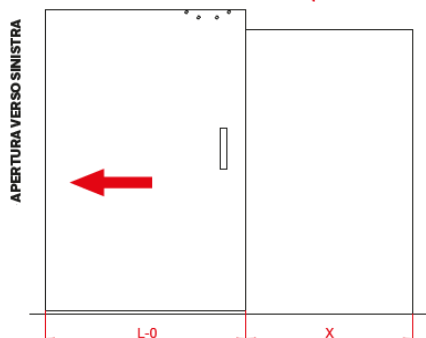

MAGIC2/1100 (K.0031.1.01)

B=0
X= MIN. 680 (L=850)
X= MAX. 930 (L=1100)

B=50
X= MIN. 680 (L=900)
X= MAX. 880 (L=1100)

MAGIC2/1800 (K.0031.2.01)

B=0
X= MIN. 680 (L=850)
X= MAX. 1630 (L=1800)

B=50
X= MIN. 680 (L=900)
X= MAX. 1580 (L=1800)

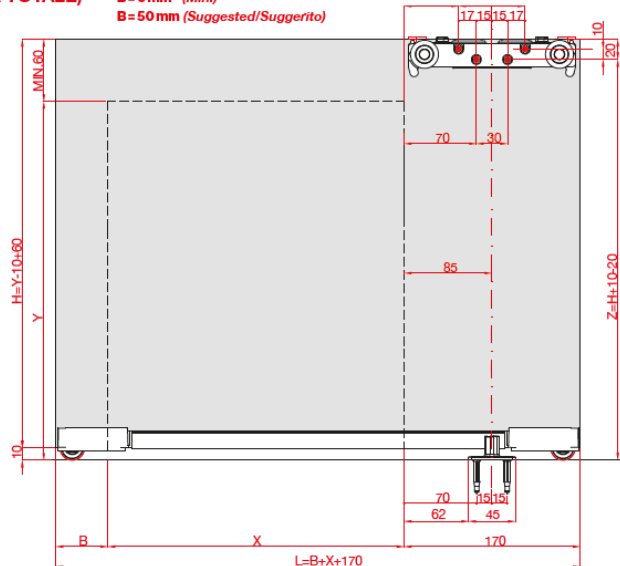

SISTEMI SCORREVOLI PER PORTE

DIVA AIR AMMORTIZZATO

Sistema scorrevole con fermi ammortizzati per porte in legno portata kg 40 e kg 80—binario di scorrimento senza copertura



ART. 1470

8 02 0.01470

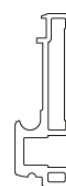

ART. 1490

8 01 2.01490

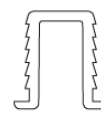

ART. 707

8 00 0.00707

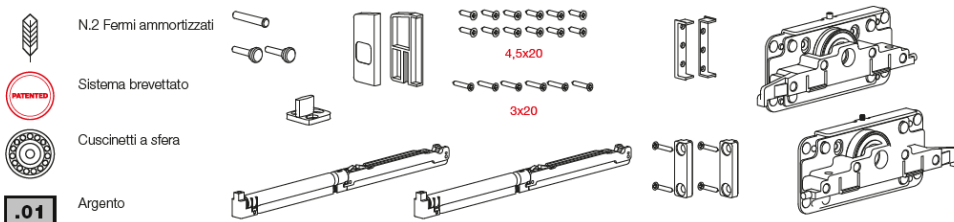

N.2 Fermi ammortizzati

Sistema brevettato

Cuscinetti a sfera

Argento

| OLD CODE | NEW CODE | COLORS COLORI | | |
|--------------|-------------|---------------------------|-------|-------|
| 1478/35G/18A | K.0053.2.01 | Anodized Silver / Argento | 40 kg | 18 mm |
| 1478/80Y/18A | K.0054.2.01 | Anodized Silver / Argento | 80 kg | 18 mm |

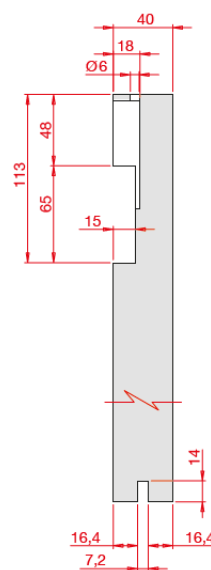
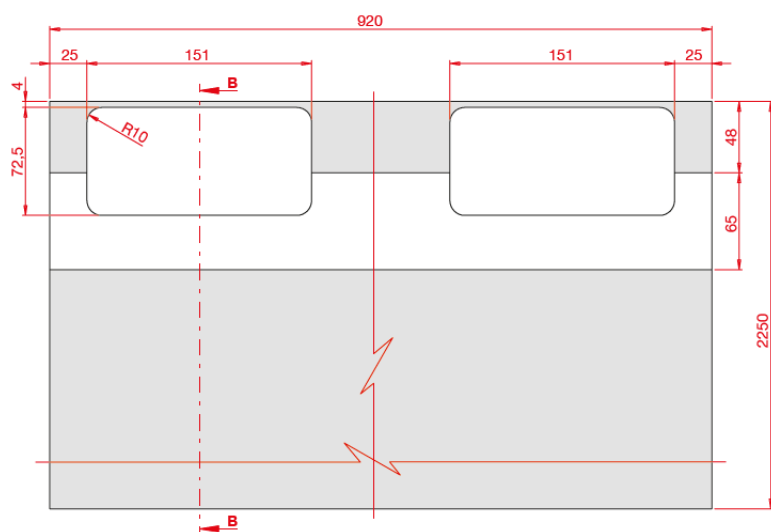

SEZIONE B-B

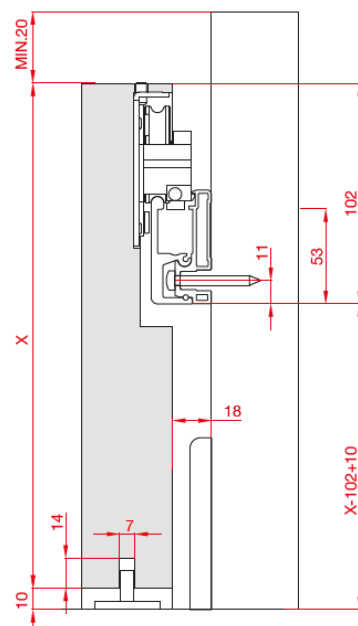

DESCRIZIONE MONTAGGIO

DESCRIZIONI MISURE

SISTEMI SCORREVOLI PER PORTE

PORTATA FINO A KG 30 staffa normale

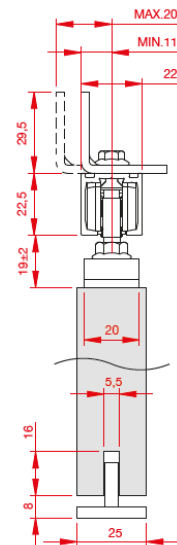
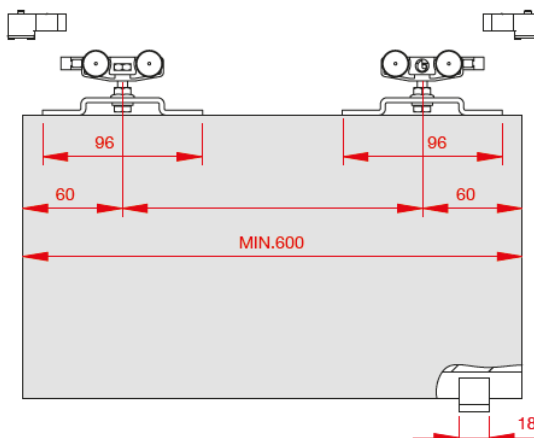
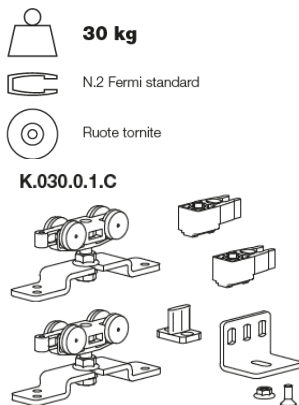
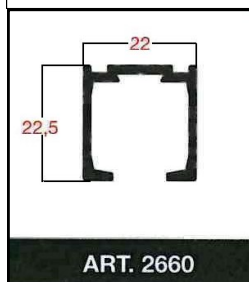

PORTATA FINO A KG 50-80-120 staffa normale

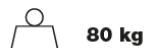
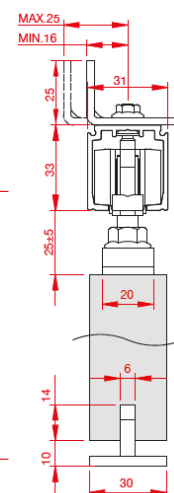
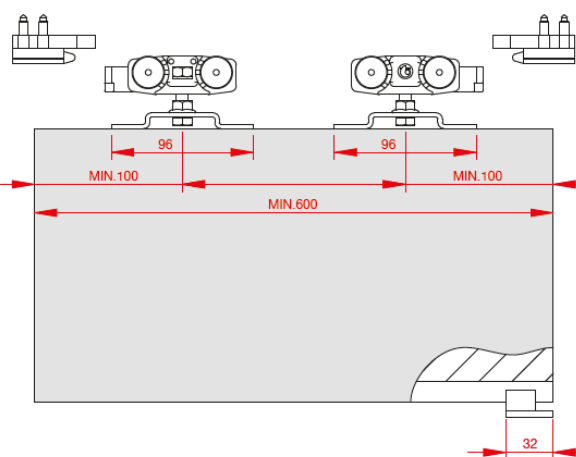
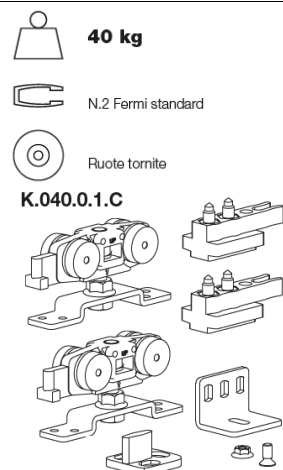
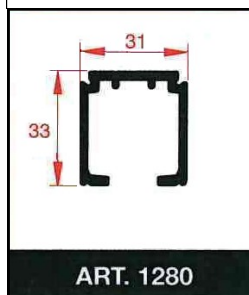

N.2 Fermi standard

Ruote tornite

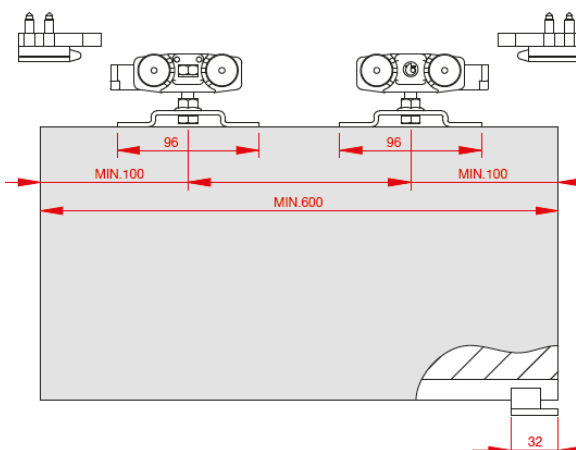
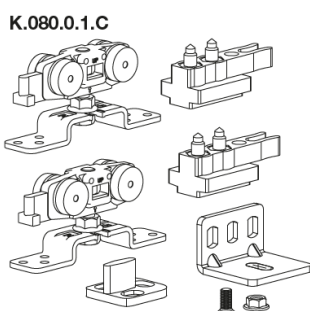

80-120 kg

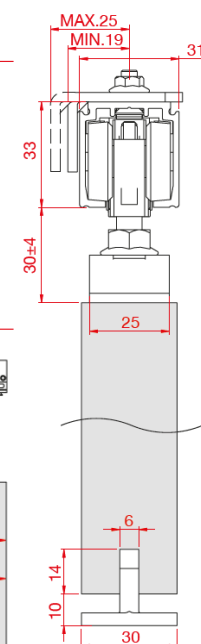

N.2 Fermi a pinza ammortizzati

Cuscinetti a sfera

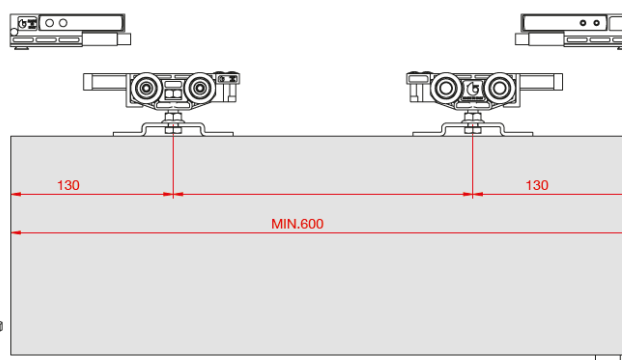
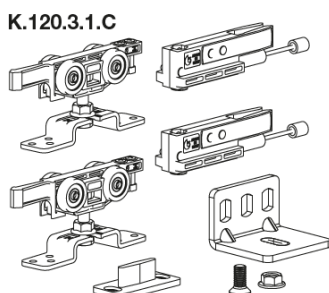

SISTEMI SCORREVOLI PER PORTE

PORTATA FINO A KG 30 staffa automatica laterale

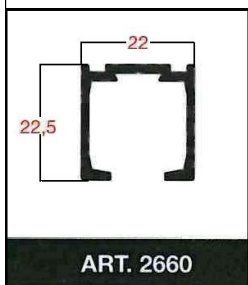

- 30 kg**
- N.2 Fermi standard
- Ruote tornite

K.030.0.4.C

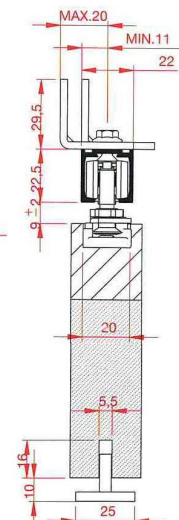
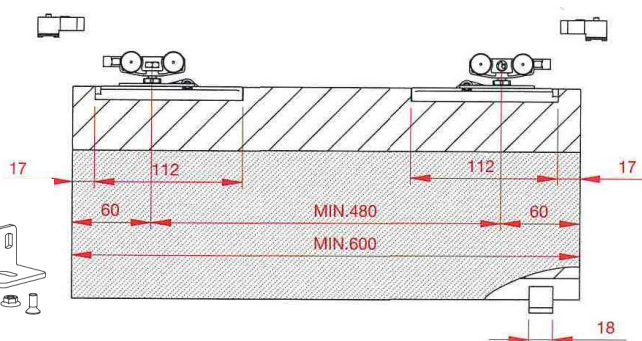
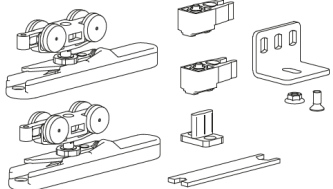

PORTATA FINO A KG 50-80-120 staffa automatica laterale

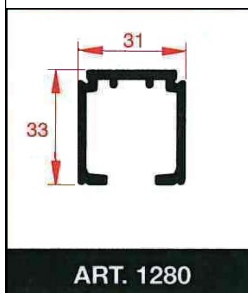

- 50 kg**
- N.2 Fermi a pinza ammortizzati
- Cuscinetti a sfera

K.050.3.4.C

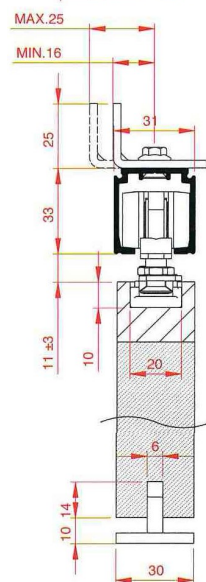
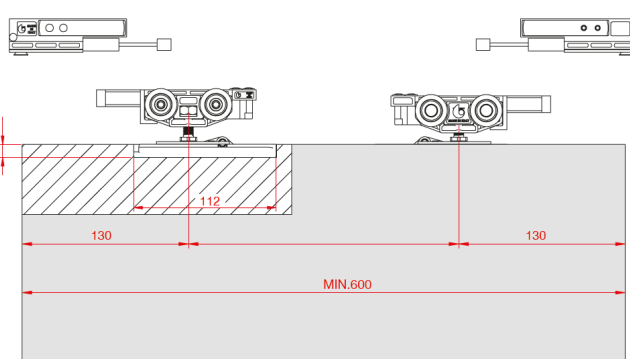
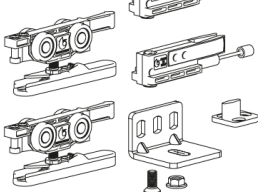

- 80 kg**
- N.2 Fermi standard
- Ruote tornite

K.080.0.4.C

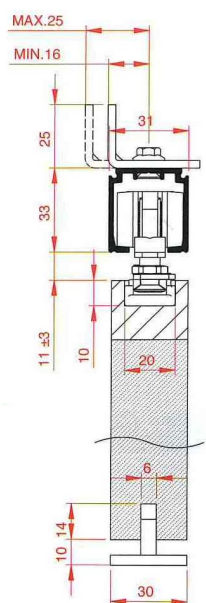
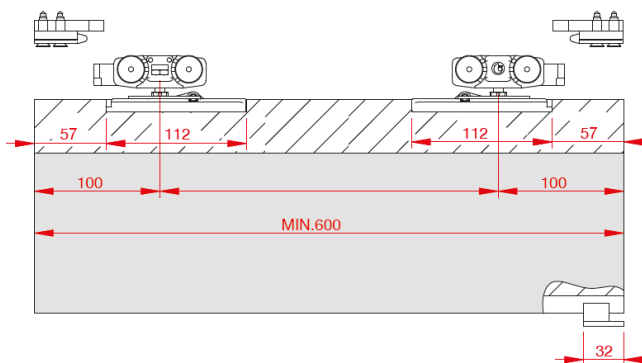
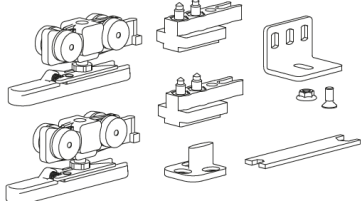

- 120 kg**
- N.2 Fermi a pinza ammortizzati
- Cuscinetti a sfera

K.120.3.4.C

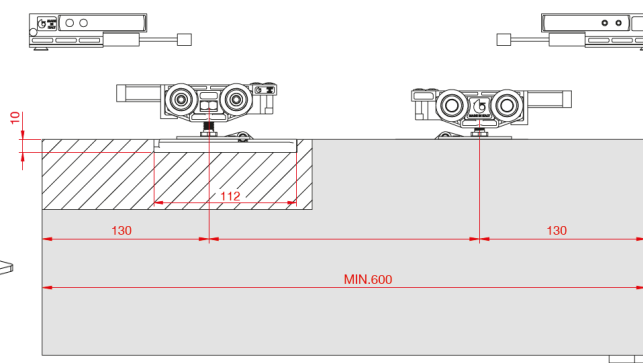
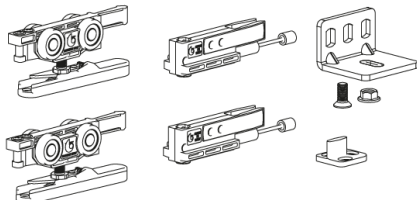

SISTEMI SCORREVOLI PER PORTE

PORTATA KG 50 e 80 staffa normale - fermi ammortizzati e idraulici

K.050.1.1.C

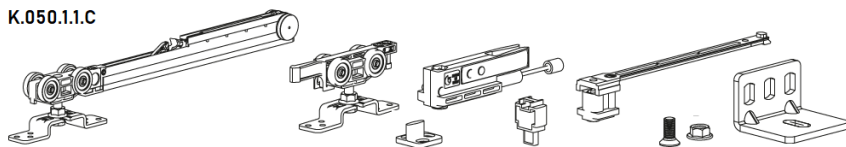

K.080.1.1.C

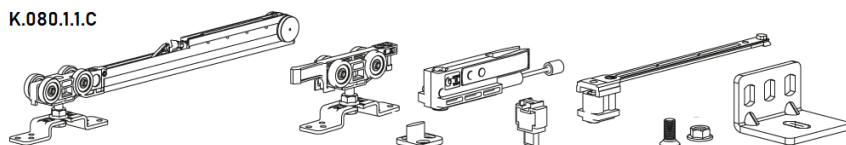

N.1 Fermo ammortizzato Fluid + N.1 Fermo a pinza ammortizzato

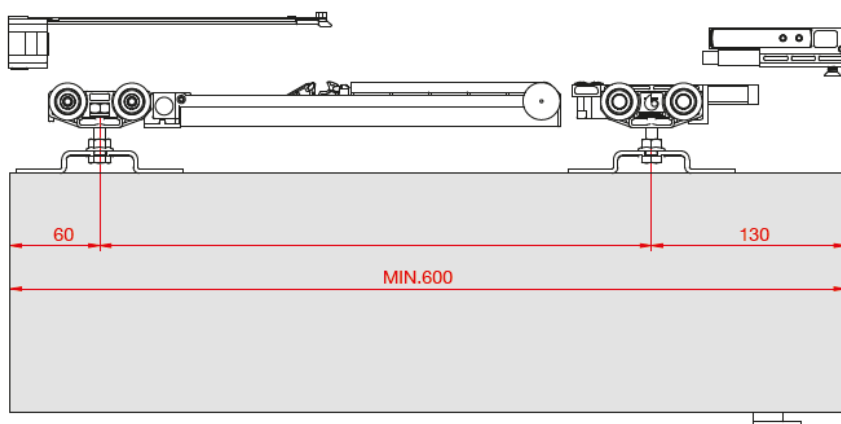

50 kg

80 kg

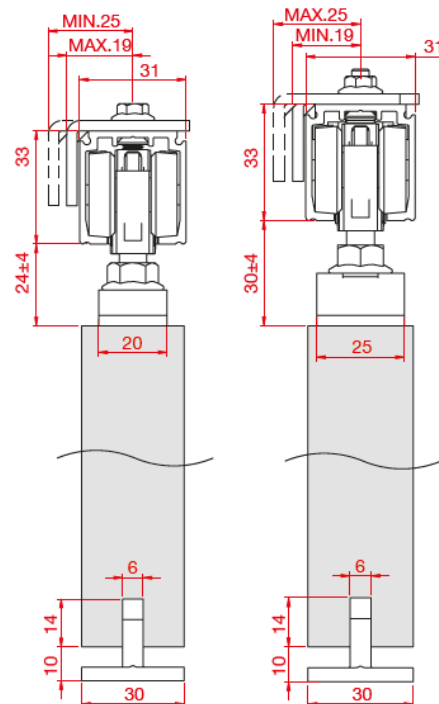

PORTATA KG 50 e KG 80 staffa normale - fermi ammortizzati

K.050.2.1.C

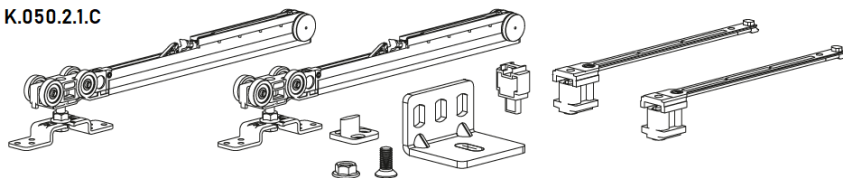

K.080.2.1.C

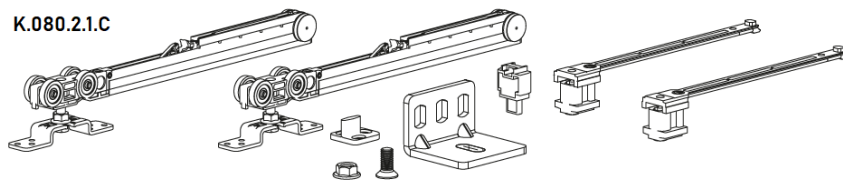

N.2 Fermi ammortizzati Fluid

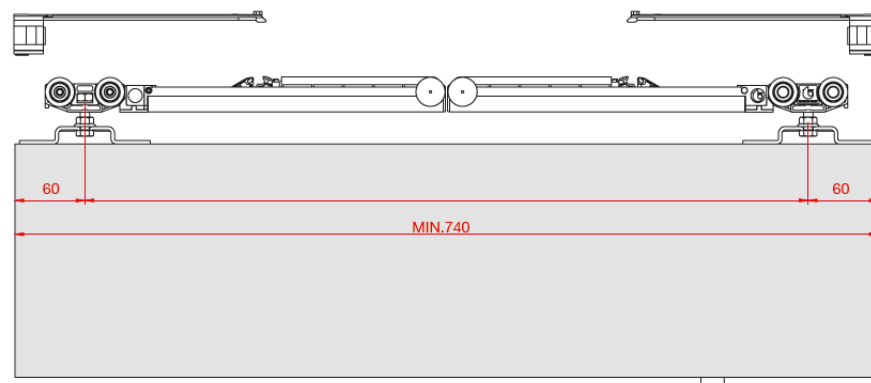

50 kg

80 kg

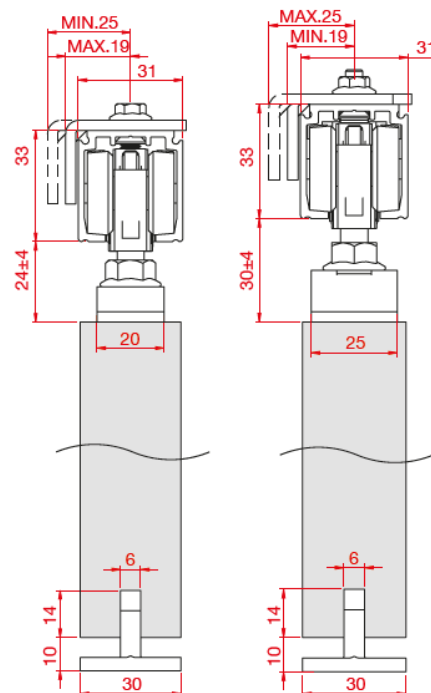

SISTEMI SCORREVOLI PER PORTE

PORTATA KG 50 e KG 80 staffa automatica - fermi ammortizzati fluid

Eclettica Scorrevoli con staffa automatica laterale

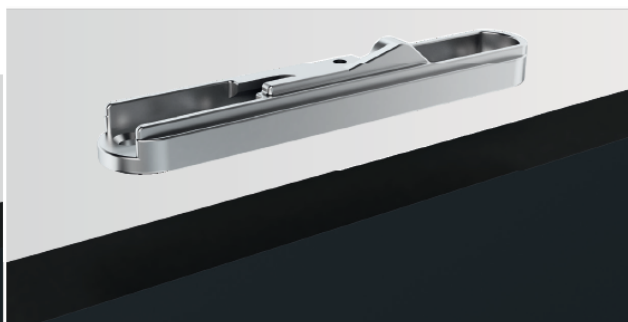
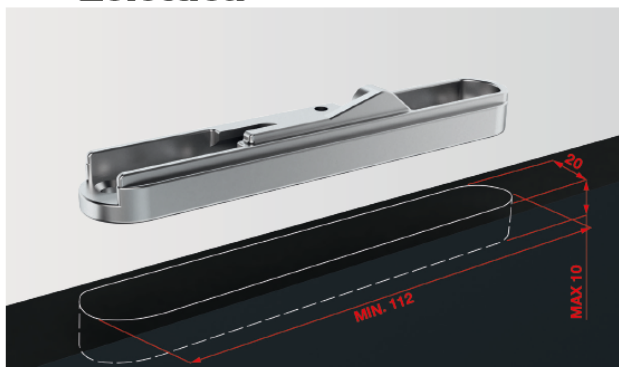

Nuova staffa ad innesto automatico laterale

Possibilità di incasso con fresata oppure fissaggio in appoggio.

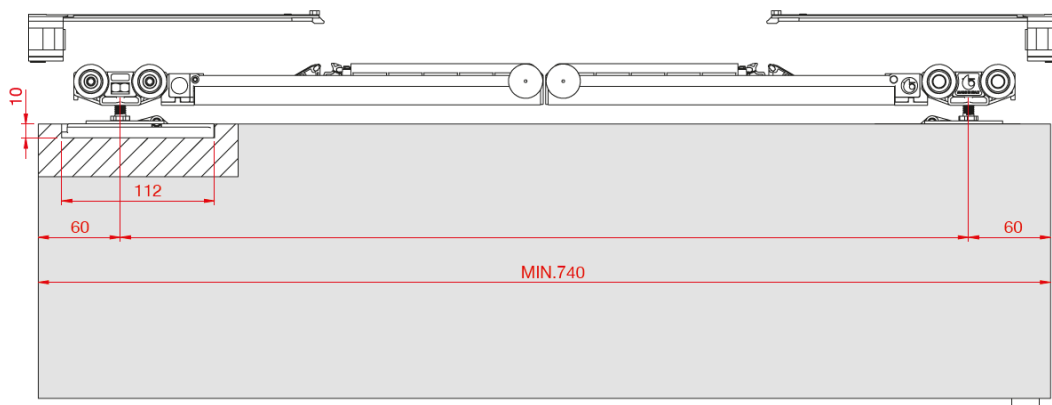
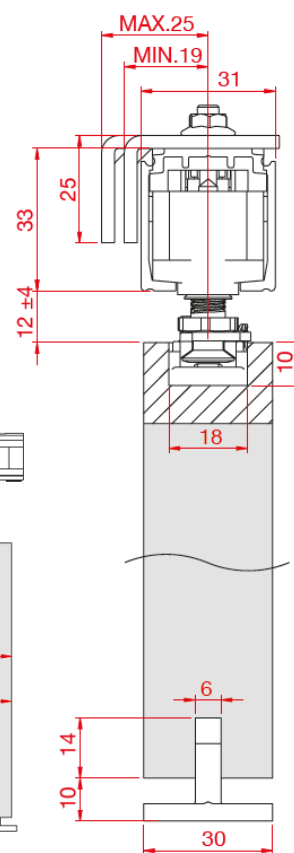
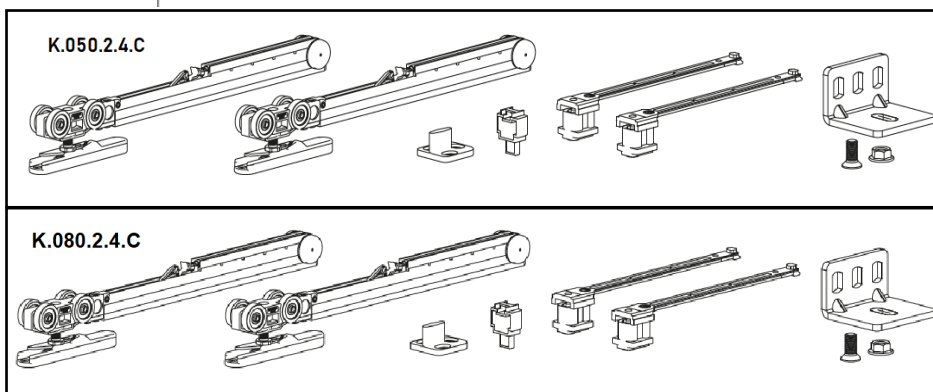
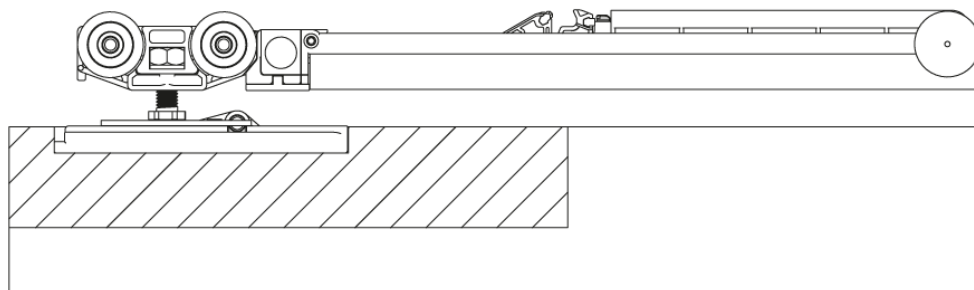

ACCESSORI PER BINARI

PROFILO COPERTURA PER BINARIO 1280

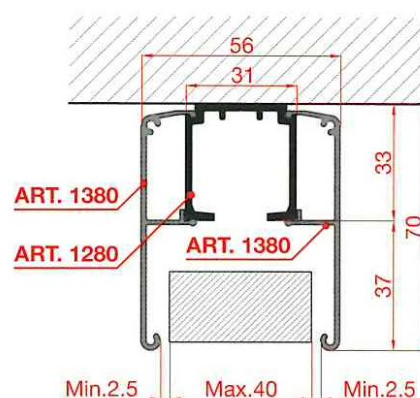
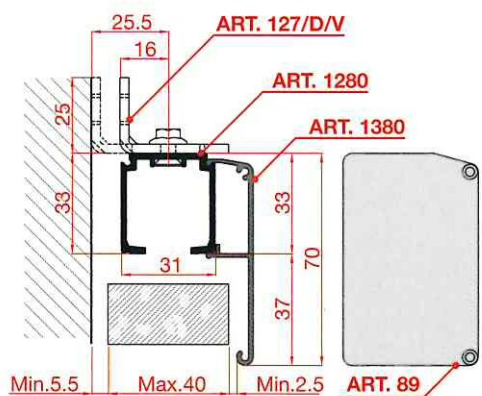

GUIDE INFERIORI

ART. 1032

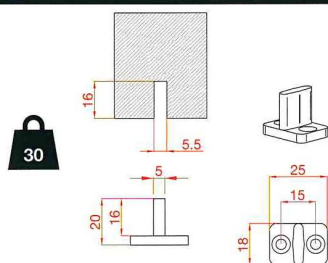

ART. 45

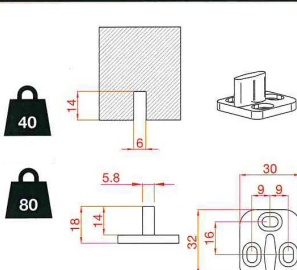

ART. 93

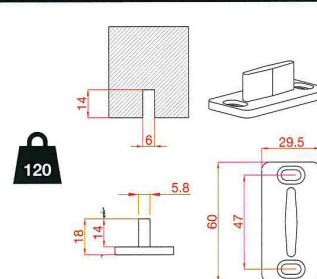

ART. 124

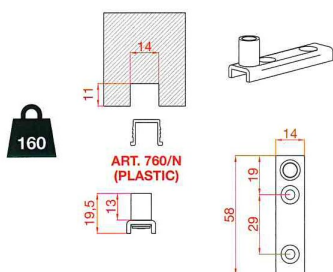

ART. 65

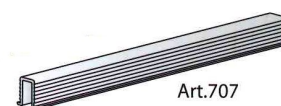
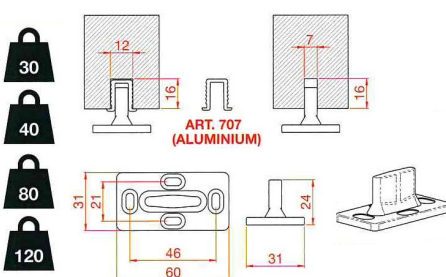

ART. 90

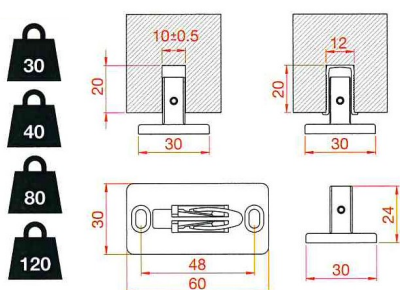

ART. 121



SPAZZOLINI PARAPOLVERE

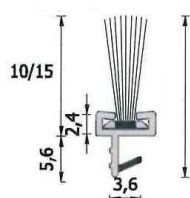

SPAZZOLINO PARAPOLVERE
CON SUPPORTO DA INCASTRO
ASTE DA MM 2150 E 2600
COLORI BIANCO-NERO-BEIGE

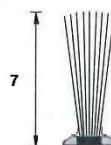

SPAZZOLINO PARAPOLVERE CON
SUPPORTO RIGIDO
CON O SENZA ADESIVO
COLORI NERO-GRIGIO

SISTEMI SCORREVOLI PER PORTE

PORTATA FINO A KG 160 STAFFA NORMALE

K.160.0.1.C

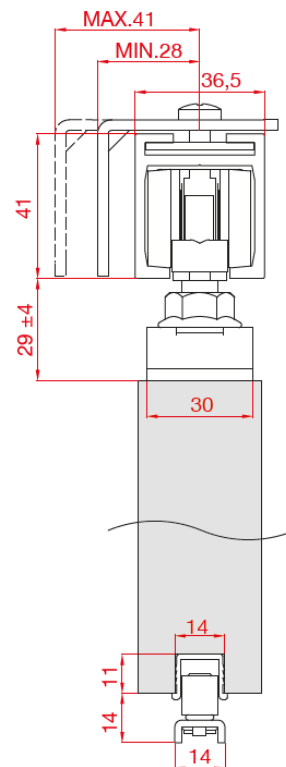
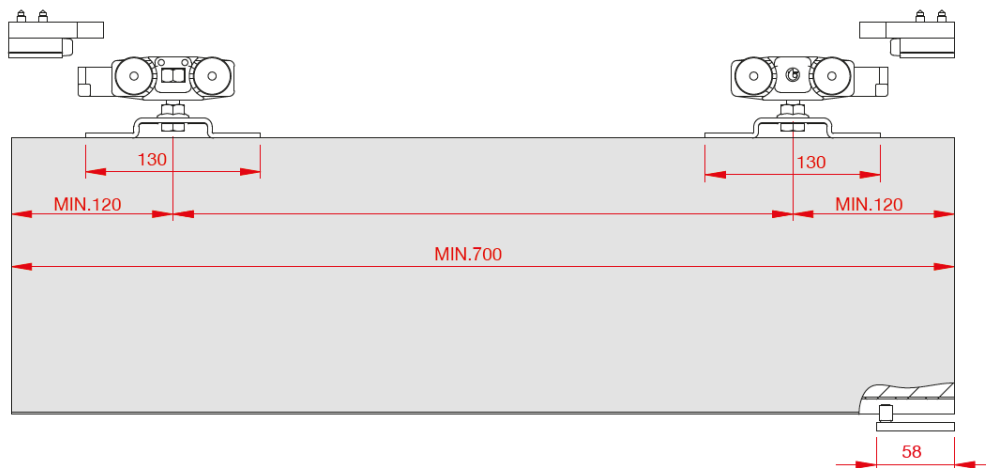
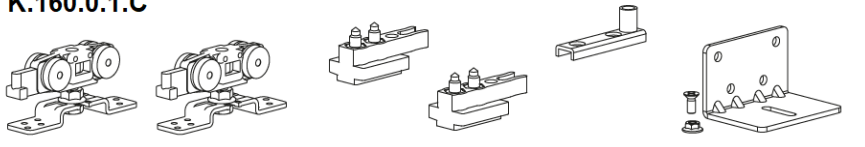

PORTATA FINO A KG 160 STAFFA AUTOMATICA

K.160.0.4.C

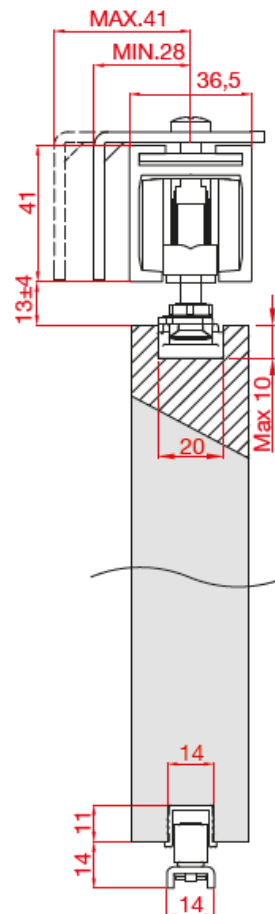
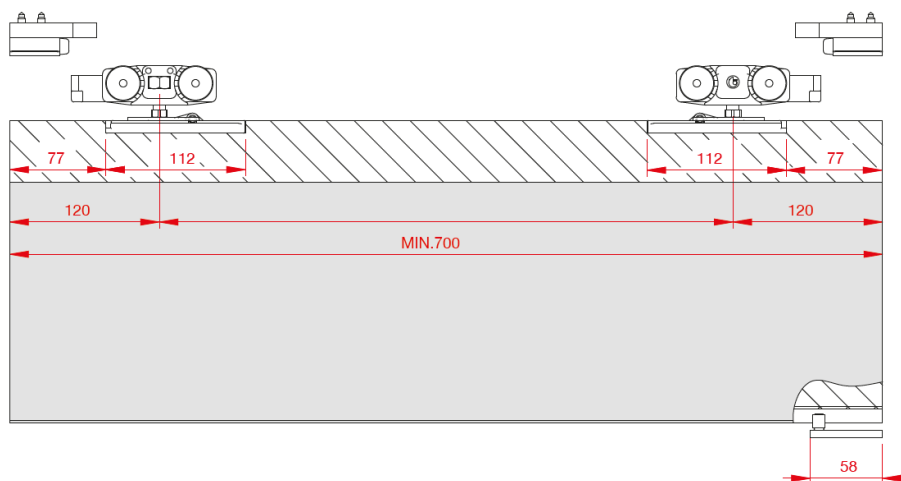
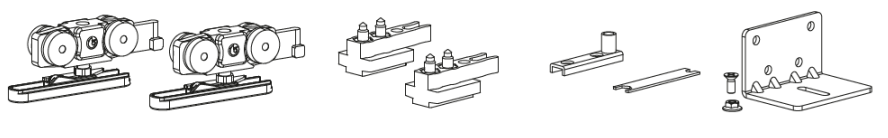

SISTEMI SCORREVOLI PER PORTE

SISTEMA SCORREVOLE CON CARRELLI CON CUSCINETTI A SFERE PORTATA KG 80/120

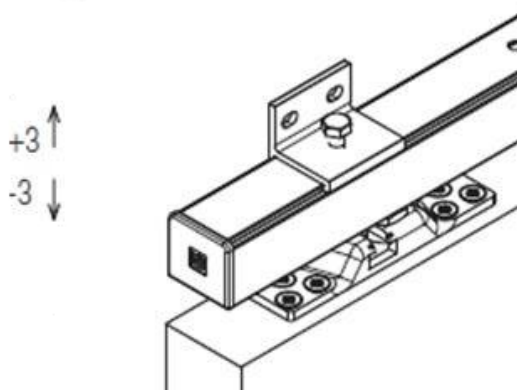
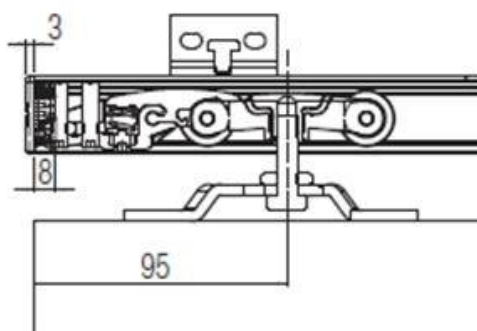
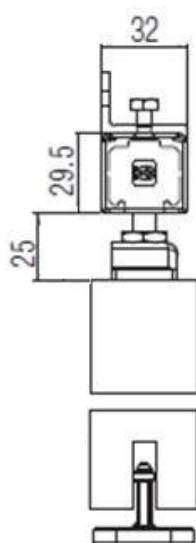
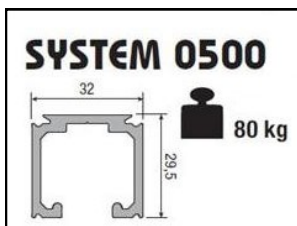

KIT Art. 0500/3



KIT Art. 0500/3 1ABS

Carrello di scorrimento
80kg con ABS



KIT Art. 0500/3 2ABS

Carrello di scorrimento
80kg con ABS

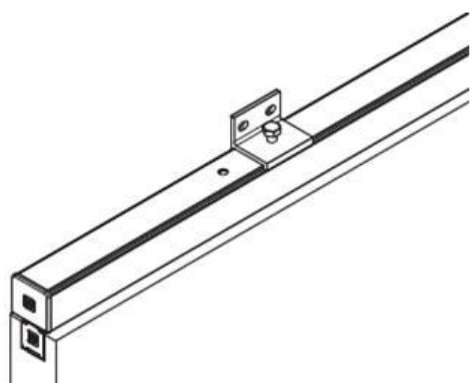
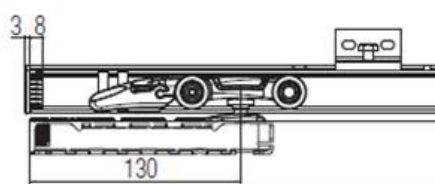
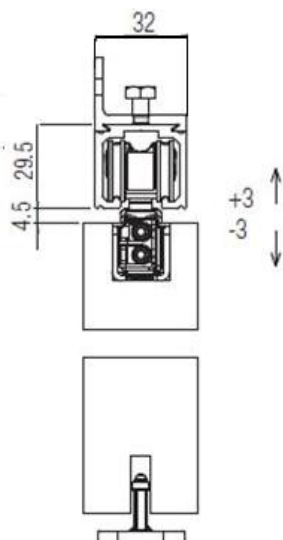
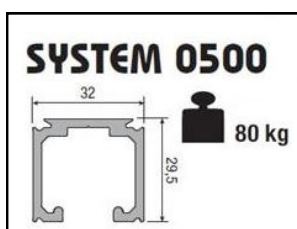

KIT Art. 0600/80



KIT Art. 0600/80 ABSU

Carrello di scorrimento
doppio con ABS



SISTEMI SCORREVOLI PER PORTE

SISTEMA SCORREVOLE PORTATA KG 80

K Art 80

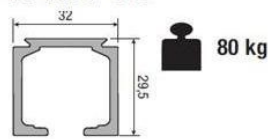

KIT Art. KART 80



2000 / 3000 / 6000

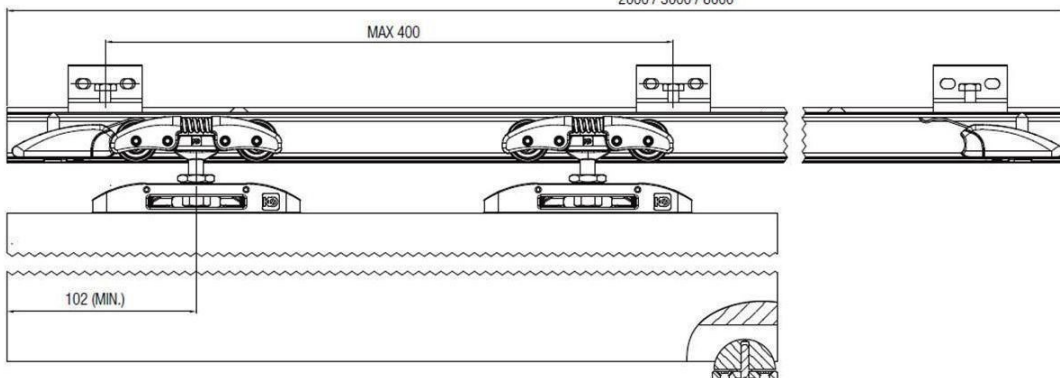
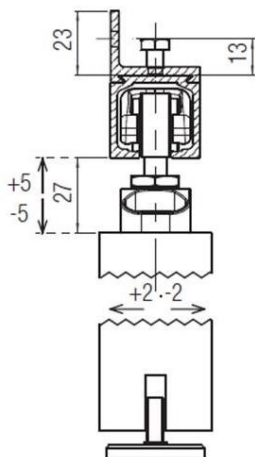

SISTEMA SCORREVOLE PER 2 ANTE IN LEGNO CON APERTURA SIMULTANEA PORTA-KG 80/120

SYSTEM 0500

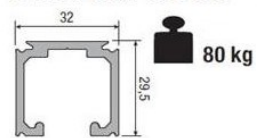

KIT Art. 0550/2

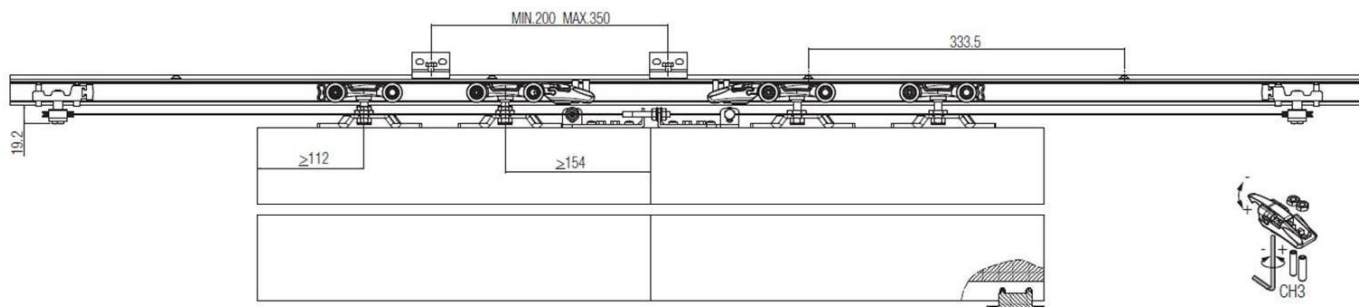
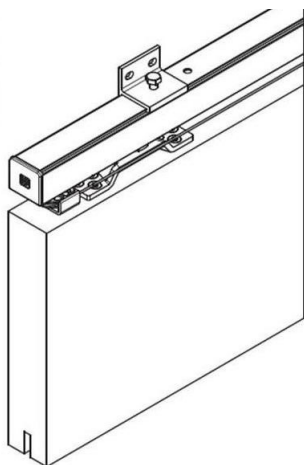
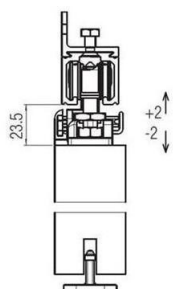
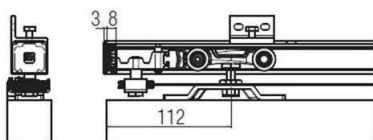

SISTEMI SCORREVOLI PER PORTE

SISTEMA SCORREVOLE PER PORTE CON ANTE PARALLELE SINGOLE PORTATA KG 80/120

SYSTEM 0500

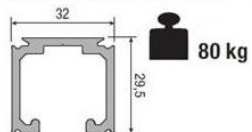

KIT Art. 0560/21

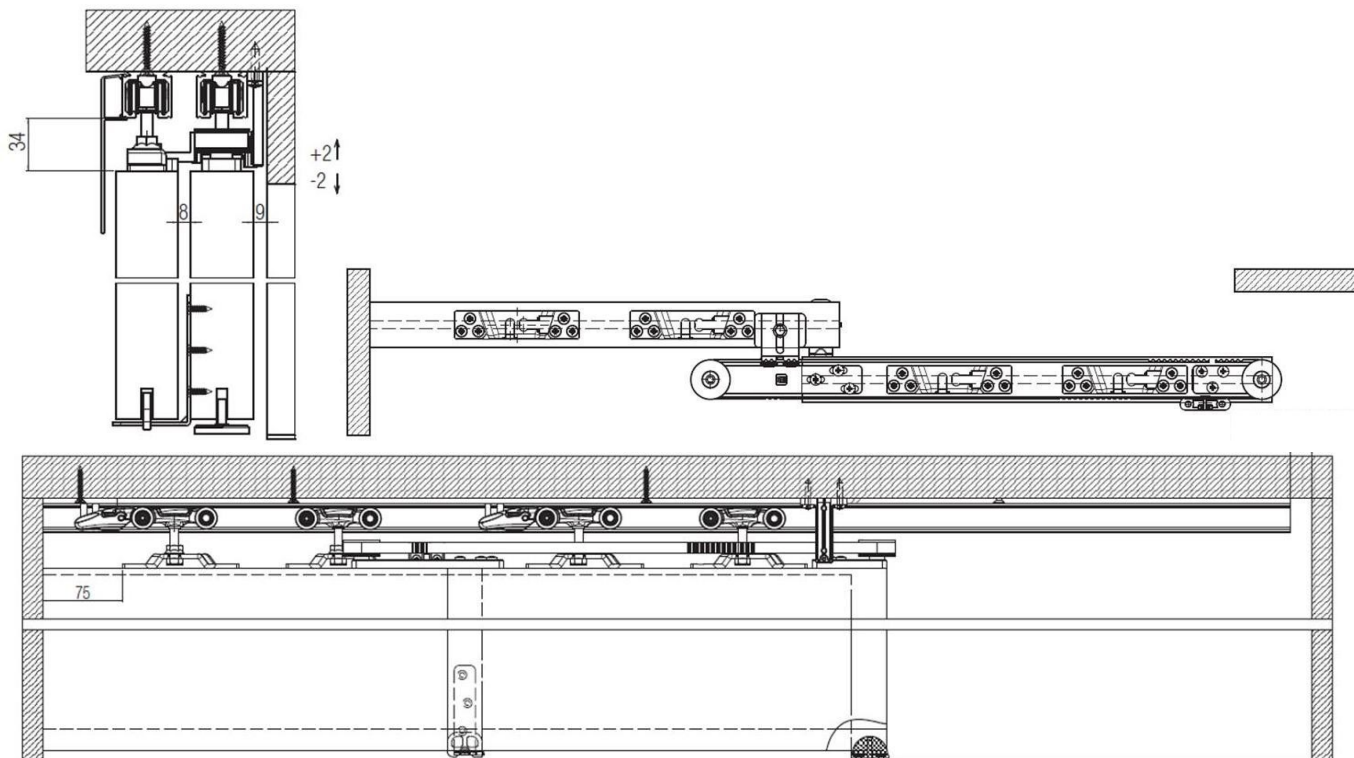

ACCESSORI

SYSTEM ABS 80
SISTEMA CHE GARANTISCE UNA CHIUSURA E UN'APERTURA DOLCE DELLA PORTA

KIT Art. 0860 80

ABS 80 kg

Attivatore ABS

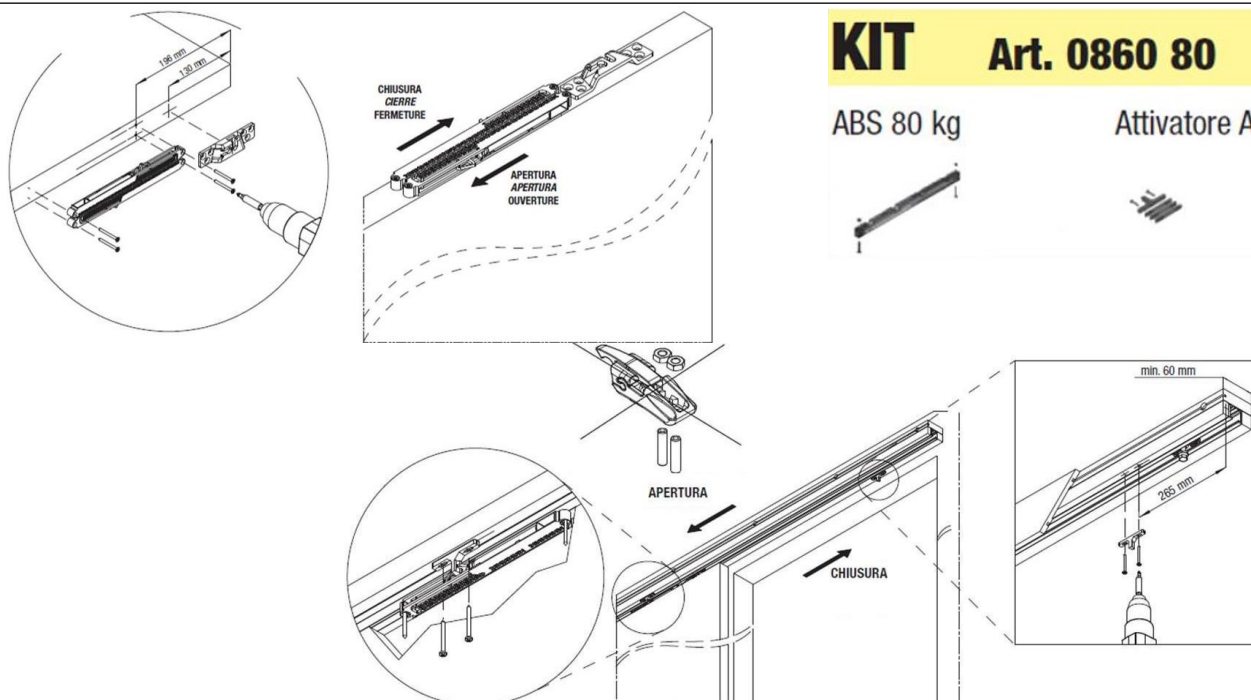

SISTEMI SCORREVOLI PER PORTE

SISTEMA SCORREVOLE PORTATA KG 175

SYSTEM 0830

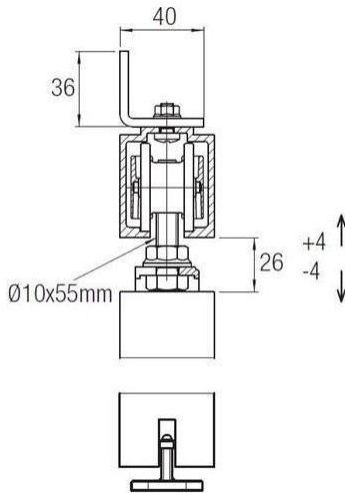
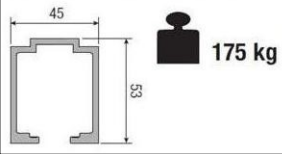

KIT Art. 0830/3

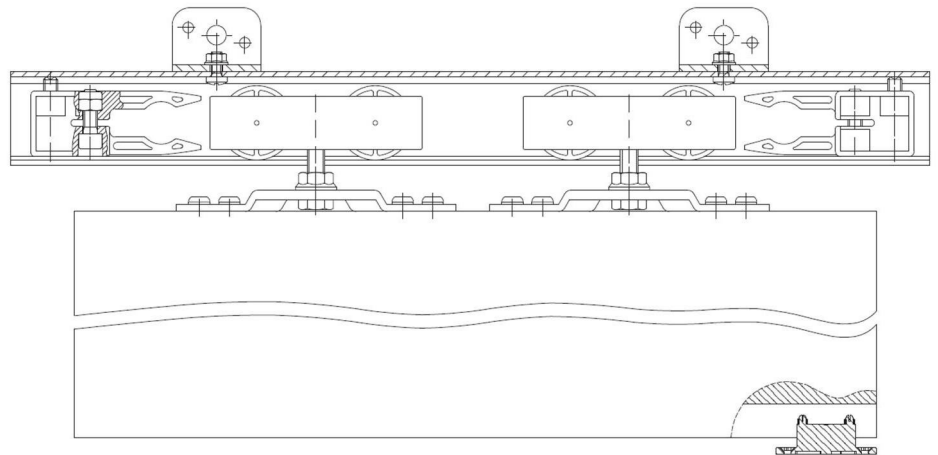

SISTEMA SCORREVOLE PORTATA KG 250

SYSTEM 0850

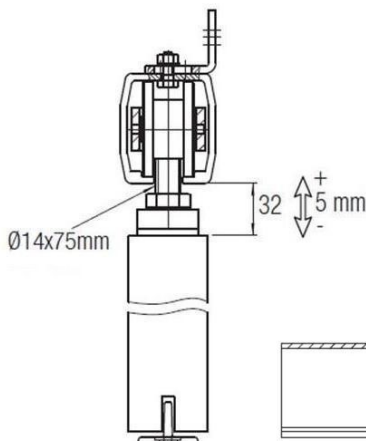
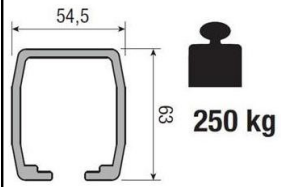

KIT Art. 0850/3

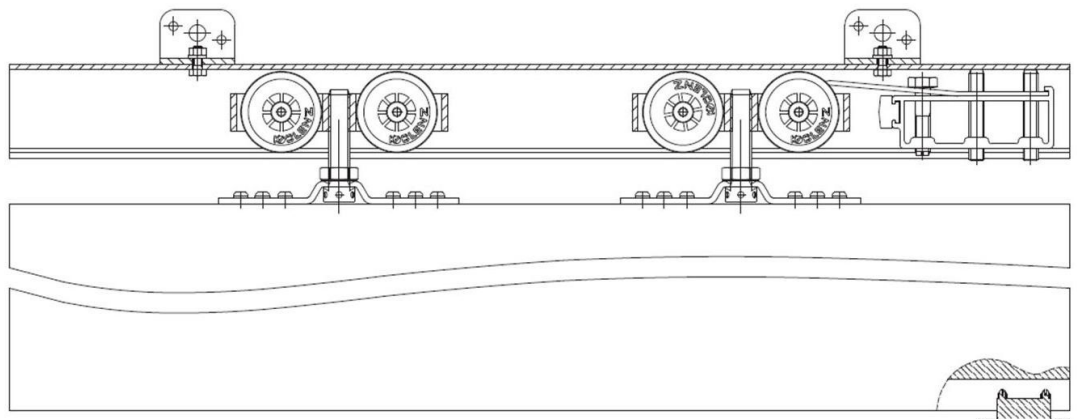

SISTEMI SCORREVOLI PER PORTE

KIT STAFFE A PINZA MM 40 PER PORTE TUTTO VETRO

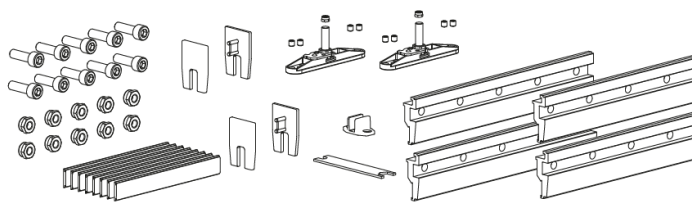

| OLD CODE | NEW CODE |  |
|-----------------|------------|---|
| 1712/10/020/ASB | K.0327.B.S | 10-10,7 mm (3/8") |

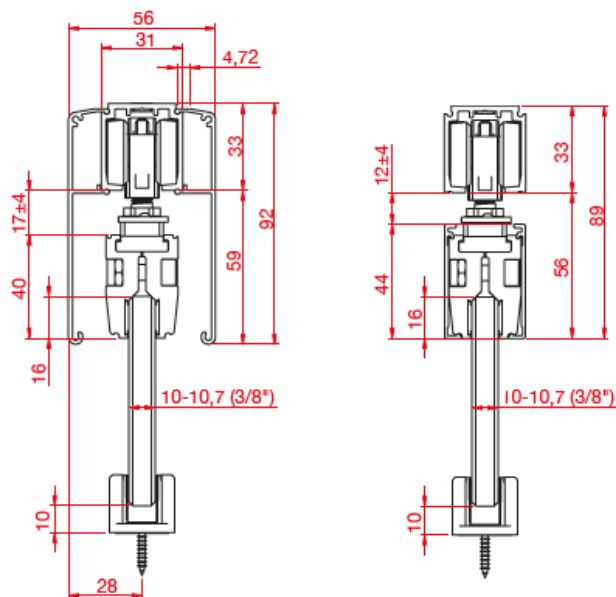

STAFFE – PINZE ECLISSE

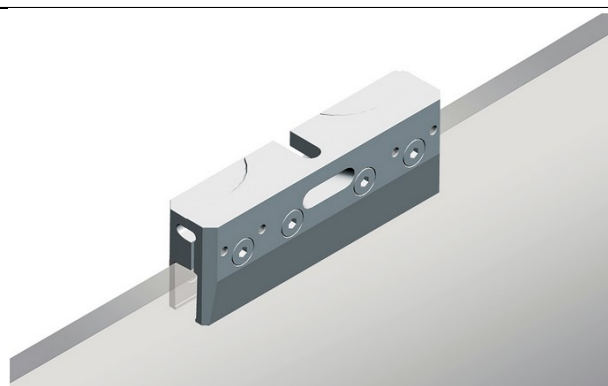
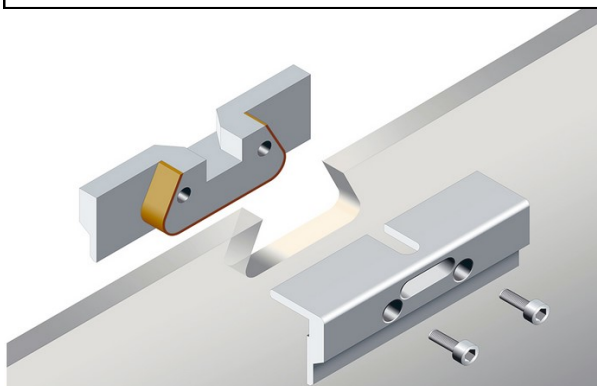

Staffe

La staffa è un supporto alternativo alla pinza che consente di applicare una porta in vetro ad un sistema di scorrimento senza stipiti e cornici coprifilo. Si installa se preventivamente sono state effettuate due incisioni "a coda di rondine" sulla parte superiore del pannello porta.

Pinze

Le pinze sono una tipologia di fissaggio per porte scorrevoli in vetro prive di finiture esterne. Non necessitano lavorazioni particolari per l'installazione, poiché si fissano direttamente sulla parte superiore della lastra in vetro. Finitura disponibile in nichelato-spazzolato.

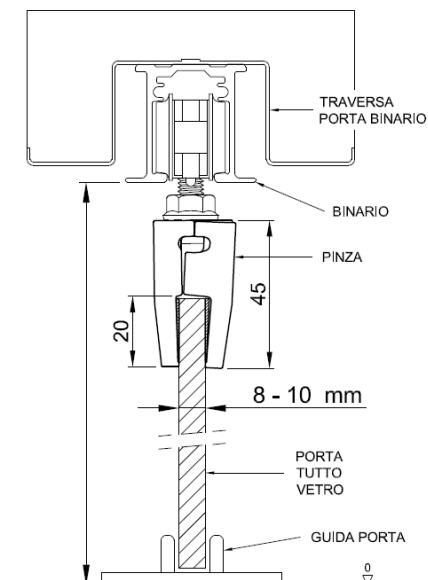
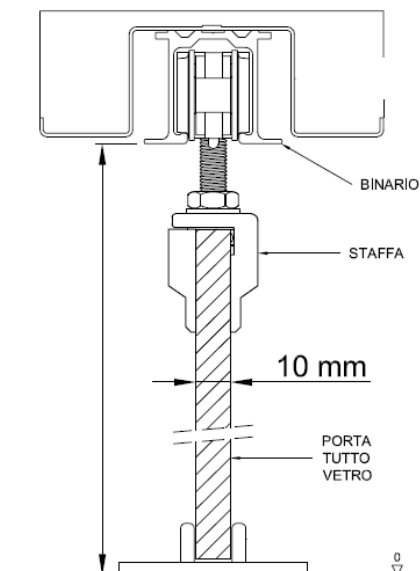

SISTEMI SCORREVOLI PER PORTE

SET ACCESSORI PER PORTE IN LEGNO AD APERTURA SIMULTANEA DA ABBINARE AL BINARIO E GUARNITURA KG 40/80 KG

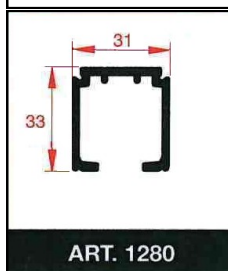

| CODE | KIT IN BOX |
|----------|------------|
| 86/87/88 | |

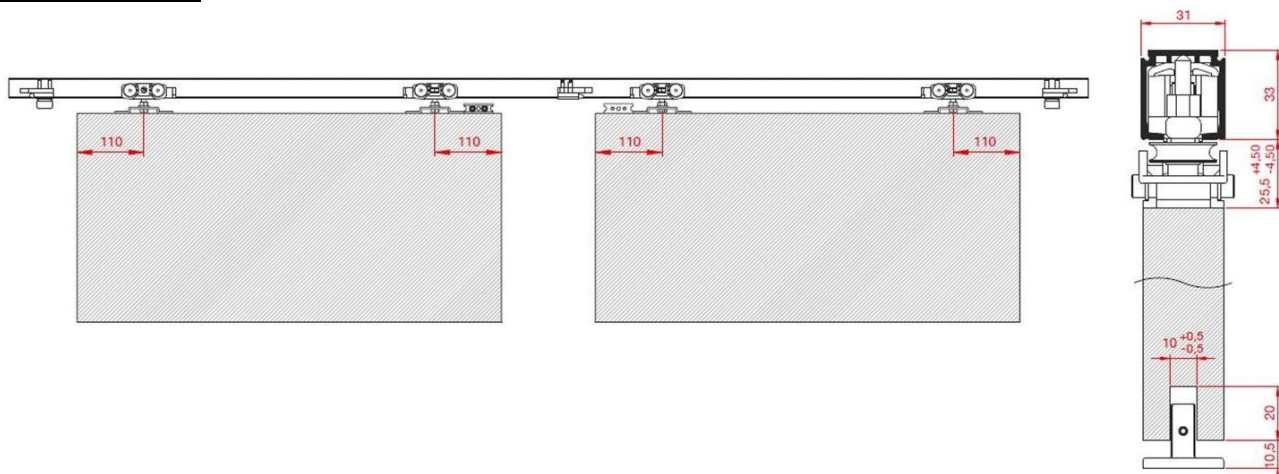

SET ACCESSORI PER PORTE A TRASCINAMENTO

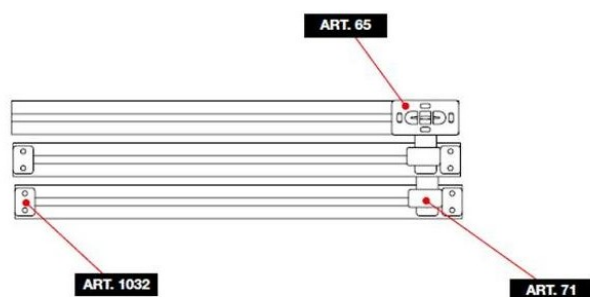

| FERMO | GUIDA INFERIORE | GUIDA INFERIORE REGOLABILE |
|-----------|-----------------|----------------------------|
| | | |
| ART. 1032 | ART. 65 | ART. 71 |

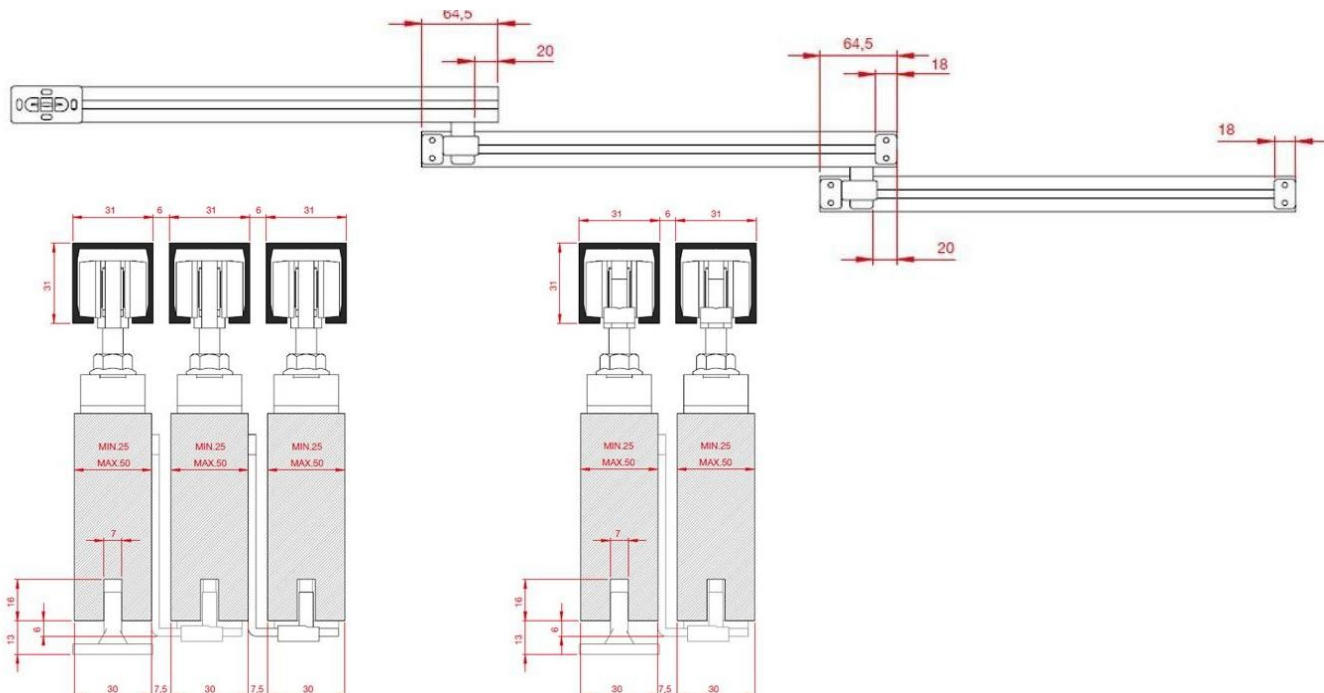

SISTEMI SCORREVOLI PER PORTE

KIT DI CHIUSURA SCORREVOLE AUTOMATICA PER ESTERNO MURO ART. 0880 1 NEW KIT

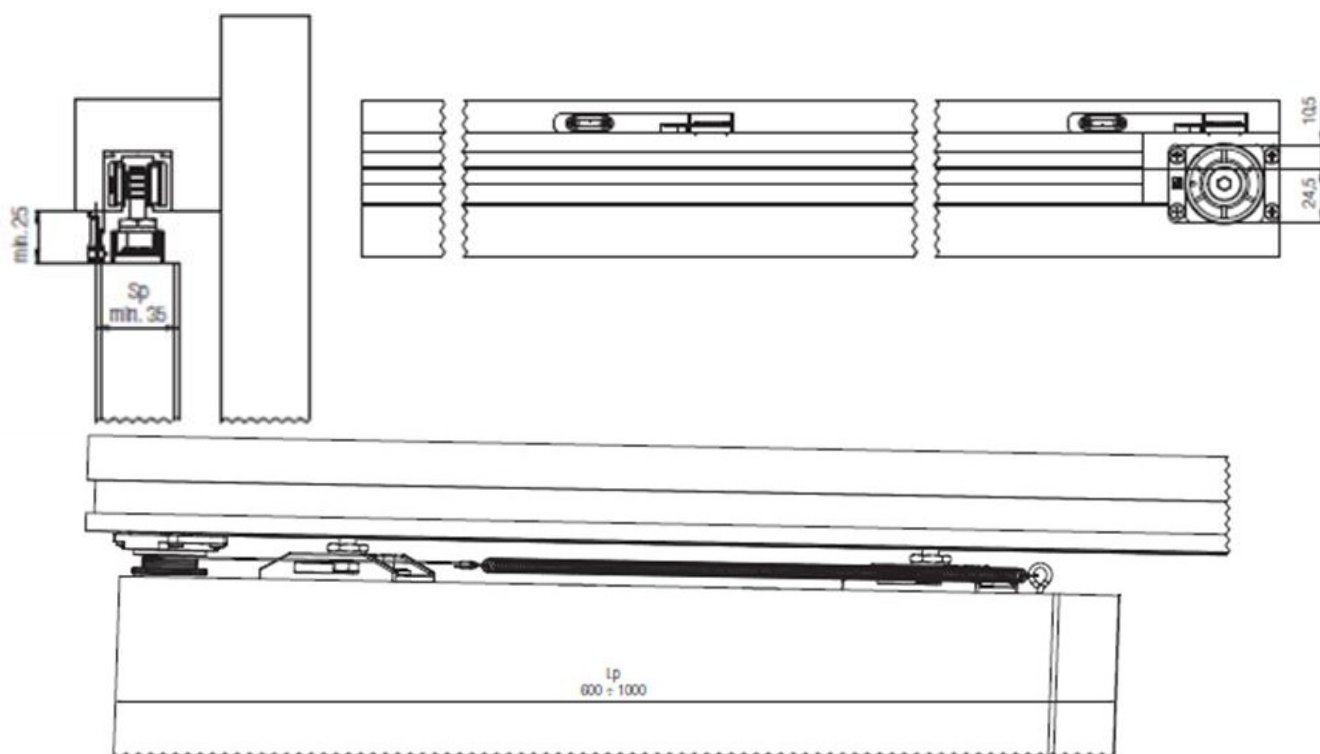

KIT DI CHIUSURA SCORREVOLE AUTOMATICA PER INTERNO MURO ART. 0880 2 NEW KIT

